

# Wellmark Series 2002PR

## “Mighty Gun” Pressure Regulator

### Application

This self-contained pressure-reducing regulator is designed for flexibility and is for low and high pressure systems. It can be used with natural gas, air, or other gases. It is primarily used to regulate pressure and volume to fuel gas valves or production instrumentation on oil and gas process equipment.

### Features

- Multiple Orifice Sizes, 316 Stainless Steel Standard
- Easy Maintenance: The top entry design allows the trim to be replaced with the body still in-line.
- Protective Cap: Tamper Resistant Pressure Setting
- Steel Body and Die Cast Aluminum Diaphragm Housing
- Body can be rotated to four positions with diaphragm housing for user convenience.
- NACE Compatible
- Utility Spring Range Available: 10 to 95 psig
- High Pressure Version Available

### Specifications

Connection ..... 1" and 2" FNPT  
 Seat Ring Orifices ..... 3/32", 1/8", 3/16", 1/4", 3/8" or 1/2"  
 Operating Temperature ..... -20°F to 180°F  
 Operating Temperature Option (High Temp) ..... -20°F to 250°F  
 Materials (NACE Compatible) ..... See Parts  
 Maximum Inlet Pressure, Differential  
 Pressure, and Outlet Pressure Ranges ..... See Table 1  
 Maximum Spring and Diaphragm  
 Housing Pressure ..... See Table 2  
 Flow Capacities ..... See Table 3, 4 & 5

### Overpressure protection

As is true with most regulators, the WellMark “Mighty Gun” Series 2002PR Regulator has an outlet pressure rating that is lower than the inlet pressure rating. Overpressure protection is needed if there is a chance that the outlet pressures could exceed the levels shown in Table 2.



**High Pressure Gas Regulator**

### Dimensional data

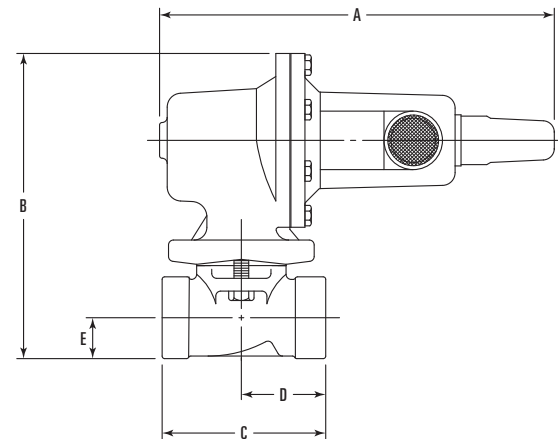

### General dimensions

Size	A	B	C	D	E
1"	9 1/16"	7 1/2"	4"	2 1/16"	1"
2"	9 1/16"	8 5/8"	5"	2 1/2"	1 2/32"

# 2002PR Table 1 and 2

## Pressure and capacity data

**Table 1. Max. pressure, differential pressure & outlet pressure ranges**

Outlet Pressure Range Spring Part No. (Color Code)	Port Diameter (Inches)	Maximum Inlet Pressure (psig) Nylon Seat	Maximum Inlet Pressure (psig) Neoprene or Viton®Seat
5 <sup>(1)</sup> to 20 psig 1117842 (YELLOW)	3/32	2000	1000
	1/8	1000	1000
	3/16	750	750
	1/4	500	500
	3/8	300	300
	1/2	250	250
15 to 40 psig 1117843 (GREEN)	3/32	2000	1000
	1/8	1500	1000
	3/16	1000	1000
	1/4	750	750
	3/8	500	500
	1/2	300	300
35 to 80 psig 1117844 (BLUE)	3/32	2000	1000
	1/8	2000	1000
	3/16	1750	1000
	1/4	1500	1000
	3/8	1000	1000
	1/2	750	750
70 to 150 psig 1117845 (RED)	3/32	2000	1000
	1/8	2000	1000
	3/16	2000	1000
	1/4	1750	1000
	3/8	1250	1000
	1/2	750	750
140 to 250 psig 1117844 (BLUE) <sup>(2)</sup>	3/32	2000	1000
	1/8	2000	1000
	3/16	1750	1000
	1/4	1500	1000
	3/8	1000	750
	1/2	750	500
240 to 500 psig 1117845 (RED) <sup>(2)</sup>	3/32	2000	1000
	1/8	2000	1000
	3/16	1750	1000
	1/4	1500	1000
	3/8	1000	1000
	1/2	750	750

1. For pressure settings under 10 psig, inlet pressure should be limited to approximately 100 psig so the set point adjustment can be reached.
2. High pressure version only.

### Capacity data

Natural gas regulating capacities for selected inlet pressures and outlet pressure settings are shown in Table 2. Flows are in scfh (60°F and 14.7 psia) of 0.6 specific gravity, natural gas at 60°F. To determine the equivalent capacities for other gases, multiply the table capacity by the following factors: for air use 0.775, for nitrogen use 0.789, for propane use 0.628, or for butane use 0.548. For gases of other specific gravities, multiply the given capacity by 0.775, and divide by the square root of the particular specific gravity.

**Table 2. Max. spring and diaphragm housing pressure**

Maximum Pressure Notes	Max. Spring and Diaphragm Pressure (psig)	
	Standard	High Pressure
Maximum pressure to avoid leakage to atmosphere other than relief action. Damage may occur to internal parts.	250	800
Maximum pressure to prevent burst of spring or diaphragm housing.	375	1500
Maximum diaphragm housing over-pressure (above set point) to avoid damage to internal parts.	60	120

# 2002PR Table 3 - Flow capacities

## 1" Standard pressure regulators

Table 3. Flow capacities in scfh of 0.6 specific gravity natural gas<sup>(1)</sup>

Outlet Pressure Range Spring Part No. (Color Code)	Outlet Press. Setting (psig)	Inlet Press (psig)	Port Diameter (Inches)						
			3/32	1/8	3/16	1/4	3/8	1/2	
5 to 20 psig 1117842 (YELLOW) <sup>(2)</sup>	5 <sup>(3)</sup>	10	170	330	710	1100	1900	2500	
		15	240	390	890	1600	2500	3350	
		20	290	500	1160	2060	3400	4450	
		30	380	670	1560	2800	4750	6900	
		60	640	1170	2600	4710	8140	13,700	
		75	770	1410	3150	5710	9790	14,500	
		100	990	1800	4070	7310	12,500	16,000	
		10	15	210	375	880	1590	2480	3300
			20	280	490	1150	2050	3380	4410
	30		380	670	1560	2800	4720	6840	
	60		640	1170	2600	4710	8140	13,700	
	75		770	1410	3150	5710	9790	14,500	
	100		990	1800	4070	7310	12,500	16,000	
	150		1420	2580	5850	10,500	17,000	18,000	
	200		1850	3370	7630	13,700	18,000	18,500	
	300		2700	4910	11,200	19,800	20,000	-	
	500	4400	8090	15,700	20,000	-	-		
	750	5400	12,000	14,000	-	-	-		
1000	5800	14,000	-	-	-	-			
1250	6300	-	-	-	-	-			
1500	6600	-	-	-	-	-			
1750	6800	-	-	-	-	-			
2000	7600	-	-	-	-	-			

- Notes:
- Capacity is based on 20% drop unless otherwise noted. See "Capacity Data" for equivalent capacities of other gases.
  - For pressure settings under 10 psig, inlet pressure should be limited to approximately 100 psig so the setpoint adjustment can be reached.
  - For pressure set point of 5 psig, the drop is 2 psig.

Outlet Pressure Range Spring Part No. (Color Code)	Outlet Press. Setting (psig)	Inlet Press (psig)	Port Diameter (Inches)						
			3/32	1/8	3/16	1/4	3/8	1/2	
35 to 80 psig 1117844 (BLUE)	60	75	700	1230	2760	4880	8630	16,100	
		100	970	1740	4010	7000	13,000	19,300	
		150	1420	2580	5850	10,500	18,900	32,800	
		200	1850	3370	7630	13,700	24,000	42,200	
		300	2700	4910	11,200	20,100	32,500	69,100	
		500	4400	8090	18,300	32,900	64,000	94,300	
		750	6600	12,000	27,200	43,380	66,900	130,000	
		1000	8700	16,000	36,100	50,300	67,700	-	
		1250	11,000	19,000	45,000	57,000	-	-	
		1500	13,000	22,000	54,000	63,000	-	-	
		1750	15,000	25,000	63,000	-	-	-	
		2000	17,000	28,000	-	-	-	-	
	80	100	900	1600	3750	6650	12,200	18,600	
		150	1410	2580	5850	10,500	21,100	33,600	
		200	1850	3370	7630	13,700	28,400	44,100	
		300	2700	4910	11,200	20,100	43,300	75,400	
		500	4400	8090	18,300	32,900	71,600	110,000	
		750	6600	12,000	27,200	48,900	105,500	135,000	
		1000	8700	16,000	36,100	64,900	118,000	-	
		1250	11,000	19,000	45,000	80,000	-	-	
		1500	13,000	22,000	54,000	96,000	-	-	
		1750	15,000	25,000	63,000	-	-	-	
		2000	17,000	28,000	-	-	-	-	
		70 to 150 psig 1117845 (RED)	100	150	1170	2510	5540	8710	16,000
200	1850			3370	7630	12,000	21,300	34,100	
300	2700			4910	11,200	19,400	30,100	53,200	
500	4400			8090	18,300	31,800	66,500	83,900	
750	6600			12,000	27,200	47,300	95,300	117,000	
1000	8700			16,000	36,100	59,700	100,000	120,000	
1250	11,000			19,000	45,000	72,000	114,000	-	
1500	13,000			22,000	54,000	86,000	-	-	
1750	15,000			25,000	63,000	95,000	-	-	
2000	17,000			28,000	71,000	-	-	-	
125	150			1250	2340	5340	9470	15,700	20,800
	200			1830	3320	7550	13,400	28,100	32,800
	300		2700	4910	11,200	20,100	36,300	52,600	
	500		4400	8090	18,300	32,900	70,800	109,000	
	750		6600	12,000	27,200	48,900	104,000	158,000	
	1000		8700	16,000	36,100	64,800	136,000	160,000	
	1250		11,000	19,000	45,000	80,000	145,000	-	
	1500		13,000	22,000	54,000	96,000	-	-	
	1750		15,000	25,000	63,000	112,000	-	-	
	2000		17,000	28,000	71,000	-	-	-	
	150		200	1760	3200	7290	12,900	21,400	33,600
			300	2700	4910	11,200	17,200	40,100	55,900
500			4400	8090	18,300	32,900	70,300	111,000	
750			6600	12,000	27,200	48,900	104,000	160,000	
1000		8700	16,000	36,100	64,800	138,000	162,000		
1250		11,000	19,000	45,000	80,000	150,000	-		
1500		13,000	22,000	54,000	96,000	-	-		
1750		15,000	25,000	63,000	112,000	-	-		
2000		17,000	28,000	71,000	-	-	-		

# 2002PR Table 4 - Flow capacities

## 2" Standard pressure regulators

Table 4. Flow capacities in scfh of 0.6 specific gravity natural gas<sup>(1)</sup>

Outlet Pressure Range Spring Part No. (Color Code)	Outlet Press. Setting (psig)	Inlet Press (psig)	Port Diameter (Inches)					
			3/32	1/8	3/16	1/4	3/8	1/2
5 to 20 psig 1117842 (YELLOW) <sup>(2)</sup>	5 <sup>(3)</sup>	10	170	330	710	1100	1700	2400
		15	240	390	890	1250	1900	2700
		20	290	500	1160	1900	2650	3900
		30	380	670	1560	2800	3680	8500
		60	640	1170	2600	4750	7250	17,800
		75	770	1410	3150	5700	8060	22,400
	100	990	1790	4070	7310	16,200	28,700	
	10	15	210	375	880	1220	1860	2670
		20	280	490	1150	1880	2610	3830
		30	380	670	1560	2760	3640	6460
		60	640	1170	2800	4750	7250	17,800
		75	770	1410	3150	5700	8060	22,400
		100	990	1790	4070	7310	16,200	28,700
		150	1420	2580	5850	10,500	23,300	25,900
		200	1850	3370	7630	13,700	22,700	24,000
		300	2700	4910	11,200	10,300	12,800	-
		500	4400	8090	18,300	21,000	-	-
		750	3600	12,000	27,200	-	-	-
		1000	8700	16,000	-	-	-	-
		1250	11,000	-	-	-	-	-
		1500	13,000	-	-	-	-	-
	1750	15,000	-	-	-	-	-	
	2000	17,000	-	-	-	-	-	
	20	30	350	620	1450	2350	4300	6110
		50	550	1000	2280	4040	7100	12,800
		60	640	1170	2640	4750	8400	15,700
		100	990	1800	4070	7310	16,200	28,700
150		1420	2580	5850	10,500	23,300	29,000	
200		1850	3370	7630	13,700	24,000	33,000	
300		2700	4910	11,200	20,100	19,600	-	
500		4400	8090	18,300	32,900	-	-	
750		6600	12,000	27,200	-	-	-	
1000		8700	16,000	-	-	-	-	
1250		11,000	-	-	-	-	-	
1500		13,000	-	-	-	-	-	
1750		15,000	-	-	-	-	-	
2000		17,000	-	-	-	-	-	
15 to 40 psig 1117843 (GREEN)	40	60	610	1090	2530	4510	8880	13,300
		75	760	1370	3080	5640	11,900	19,000
		100	990	1790	4070	7310	16,200	25,400
		150	1420	2580	5850	10,500	23,300	41,300
		200	1850	3370	7630	13,700	30,400	53,900
		300	2700	4910	11,200	20,100	44,600	48,000
		500	4400	8090	18,300	32,900	22,000	-
		750	6600	12,000	27,200	28,000	-	-
		1000	8700	16,000	36,100	-	-	-
		1250	11,000	19,000	-	-	-	-
		1500	13,000	22,000	-	-	-	-
		1750	15,000	-	-	-	-	-
		2000	17,000	-	-	-	-	-

Outlet Pressure Range Spring Part No. (Color Code)	Outlet Press. Setting (psig)	Inlet Press (psig)	Port Diameter (Inches)							
			3/32	1/8	3/16	1/4	3/8	1/2		
35 to 80 psig 1117844 (BLUE)	60	75	700	1230	2760	4900	9000	12,300		
		100	970	1740	4010	7000	15,000	20,400		
		150	1420	2580	5850	10,500	23,300	35,200		
		200	1850	3370	7630	13,700	30,400	53,900		
		300	2700	4910	11,200	20,100	44,600	79,000		
		500	4400	8090	18,300	32,900	73,000	38,800		
		750	6600	12,000	27,200	48,900	53,000	32,000		
		1000	8700	16,000	36,100	43,000	52,000	-		
		1250	11,000	19,000	45,000	70,000	-	-		
		1500	13,000	22,000	54,000	43,000	-	-		
		1750	15,000	25,000	63,000	-	-	-		
		2000	17,000	28,000	-	-	-	-		
		80	100	900	1600	3750	6400	12,000	20,400	
			150	1410	2580	5850	10,500	23,300	41,300	
	200		1850	3370	7630	13,700	30,400	53,900		
	300		2700	4910	11,200	20,100	44,600	79,000		
	500		4400	8090	18,300	32,900	73,000	48,000		
	750		6600	12,000	27,200	48,900	87,000	44,000		
	1000		8700	16,000	36,100	65,000	63,000	-		
	1250		11,000	19,000	45,000	63,000	-	-		
	1500		13,000	22,000	54,000	86,000	-	-		
	1750		15,000	25,000	63,000	-	-	-		
	2000		17,000	28,000	-	-	-	-		
	70 to 150 psig 1117845 (RED)		100	150	1170	2510	5540	8600	16,000	22,000
				200	1850	3370	7630	13,700	22,000	33,000
		300		2700	4910	11,200	20,100	35,000	65,300	
		500		4400	8090	18,300	32,900	73,000	129,000	
750		6600		12,000	27,200	48,900	108,000	59,000		
1000		8700		16,000	36,100	64,800	82,000	-		
1250		11,000		19,000	45,000	80,000	110,000	-		
125		1500	13,000	22,000	54,000	96,000	-	-		
		1750	15,000	25,000	63,000	112,000	-	-		
		2000	17,000	28,000	71,000	-	-	-		
		150	150	1250	2340	5340	8600	16,000	24,000	
			200	1830	3320	7550	13,400	24,000	36,000	
			300	2700	4910	11,200	20,100	39,000	65,300	
			500	4400	8090	18,300	32,900	73,000	129,000	
750	6600		12,000	27,200	48,900	108,000	59,000			
1000	8700		16,000	36,100	64,800	58,000	-			
1250	11,000		19,000	45,000	80,000	75,000	-			
150	1500	13,000	22,000	54,000	96,000	-	-			
	1750	15,000	25,000	63,000	112,000	-	-			
	2000	17,000	28,000	71,000	-	-	-			
	200	1760	3200	7290	13,000	24,000	38,000			
	300	2700	4910	11,200	20,100	44,600	64,200			
	500	4400	8090	18,300	32,900	73,000	129,000			
	750	6600	12,000	27,200	48,900	108,000	62,000			
1000	8700	16,000	36,100	64,800	144,000	-				
1250	11,000	19,000	45,000	80,000	81,000	-				
1500	13,000	22,000	54,000	96,000	-	-				
1750	15,000	25,000	63,000	112,000	-	-				
2000	17,000	28,000	71,000	-	-	-				

- Notes:
- Capacity is based on 20% drop unless otherwise noted. See "Capacity Data" for equivalent capacities of other gases.
  - For pressure settings under 10 psig, inlet pressure should be limited to approximately 100 psig so the setpoint adjustment can be reached.
  - For pressure set point of 5 psig, the drop is 2 psig.

# 2022PR Table 4 - Flow capacities continued

## 2" High pressure regulators

Table 4 (continued). Flow capacities in scfh of 0.6 specific gravity natural gas<sup>(1)</sup>

Outlet Pressure Range Spring Part No. (Color Code)	Outlet Press. Setting (psig)	Inlet Press (psig)	Port Diameter (Inches)					
			3/32	1/8	3/16	1/4	3/8	1/2
140 to 250 psig 1117844 (BLUE) <sup>(2)</sup>	150	200	1760	3200	7290	13,700	24,100	31,000
		250	2260	4100	9200	18,100	28,600	40,000
		300	2700	4910	11,200	19,300	31,000	46,000
		400	3600	6500	14,800	25,000	40,000	50,000
		500	4400	8090	18,300	32,000	-	-
		750	6600	12,000	27,200	48,000	-	-
		1000	8700	16,000	36,100	65,000	-	-
		1250	11,000	19,000	45,000	-	-	-
		1500	13,000	22,000	54,000	-	-	-
		1750	15,000	25,000	63,000	-	-	-
		2000	17,000	28,000	-	-	-	-
	200	250	2160	3850	8400	16,100	33,000	41,000
		300	2700	4910	11,200	20,100	36,000	52,000
		400	2600	6500	14,800	26,500	52,000	68,000
		500	4400	8090	19,300	33,000	61,000	-
		750	6600	12,000	27,200	49,000	-	-
		1000	8700	16,000	36,100	65,000	-	-
		1250	11,000	19,000	45,000	-	-	-
		1500	13,000	22,000	54,000	-	-	-
		1750	15,000	25,000	63,000	-	-	-
		2000	17,000	28,000	-	-	-	-
		20	300	2500	4500	9900	18,500	37,000
	400		3600	6400	14,300	26,000	55,000	81,000
	500		4400	8090	18,300	33,000	64,000	95,000
750	6600		12,000	27,200	49,000	102,000	-	
1000	8700		16,000	36,100	65,000	-	-	
1250	11,000		19,000	45,000	81,000	-	-	
1500	13,000		22,000	54,000	-	-	-	
1750	15,000		25,000	63,000	-	-	-	
2000	17,000		28,000	71,000	-	-	-	

Outlet Pressure Range Spring Part No. (Color Code)	Outlet Press. Setting (psig)	Inlet Press (psig)	Port Diameter (Inches)					
			3/32	1/8	3/16	1/4	3/8	1/2
240 to 500 psig 1117845 (RED) <sup>(2)</sup>	250	300	2500	4500	9300	14,000	25,000	37,000
		400	3600	6400	14,300	21,400	36,000	49,000
		500	4400	8090	18,300	26,300	42,000	62,000
		750	6600	12,000	27,200	37,100	57,000	-
		1000	8700	16,000	36,100	47,400	-	-
		1250	11,000	19,000	45,000	57,000	-	-
		1500	13,000	22,000	54,000	-	-	-
		2000	17,000	28,000	71,000	-	-	-
	300	350	2900	5150	11,300	18,400	31,000	45,000
		400	3500	6200	13,700	23,400	40,000	52,000
		500	4400	8090	18,300	32,000	53,000	67,000
		750	6600	12,000	27,200	48,000	80,000	-
		1000	8700	16,000	36,100	62,000	-	-
		1250	11,000	19,000	45,000	79,000	-	-
		1500	13,000	22,000	54,000	-	-	-
		2000	17,000	28,000	71,000	-	-	-
	400	450	3600	6400	14,000	25,000	47,000	67,000
		500	4400	8090	18,300	32,000	54,000	77,000
		750	6600	12,000	27,200	49,000	91,000	-
		1000	8700	16,000	36,100	65,000	-	-
		1250	11,000	19,000	45,000	81,000	-	-
		1500	13,000	22,000	54,000	-	-	-
		1750	15,000	25,000	63,000	-	-	-
		2000	17,000	28,000	71,000	-	-	-
500	550	4300	7700	16,800	33,000	62,000	90,000	
	600	4900	8800	19,400	37,000	70,000	104,000	
	750	6600	12,000	27,200	49,000	88,000	140,000	
	1000	8700	16,000	36,100	65,000	130,000	-	
	1250	11,000	19,000	45,000	81,000	-	-	
	1500	13,000	22,000	54,000	97,000	-	-	
	1750	15,000	25,000	63,000	-	-	-	
	2000	17,000	28,000	71,000	-	-	-	

Notes:

- Capacity is based on 20% drop unless otherwise noted. See "Capacity Data" for equivalent capacities of other gases.
- High pressure version only.

# Model number

## Determining the model number

Example given: A 1" Model 2002PR Pressure Regulator with an Outlet Pressure Range of 70 to 150 psig, 316 S.S./Neoprene Nace Trim with a 1/4" Seat Ring Orifice in the standard model option.

# MODEL 2002 1 PR-4 S 25 S

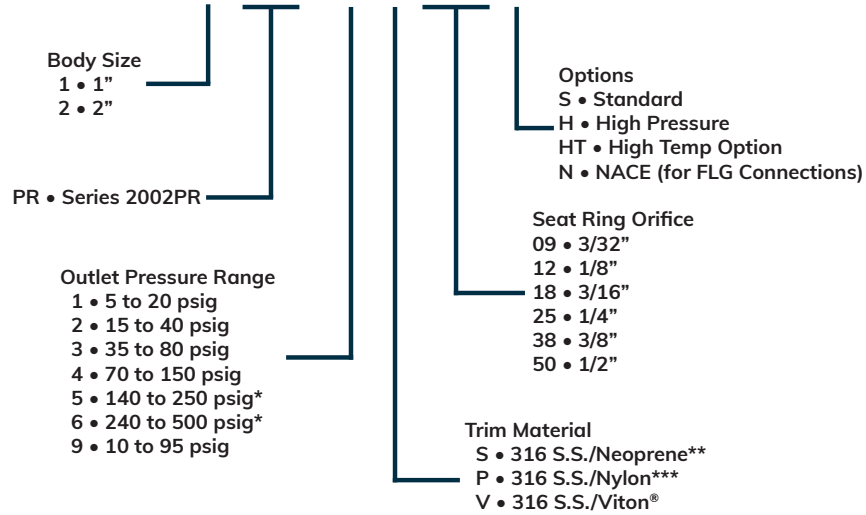

\*High pressure option only.

\*\*WellMark standard regulator option meets NACE requirements.

\*\*\*Requires inlet pressures above 1000 psi, outlet pressures over 35psi and orifices smaller than 3/8

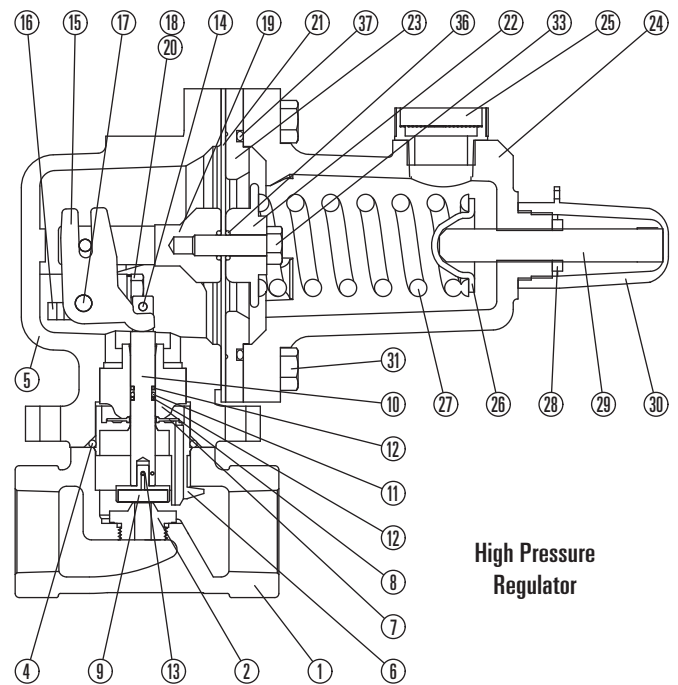
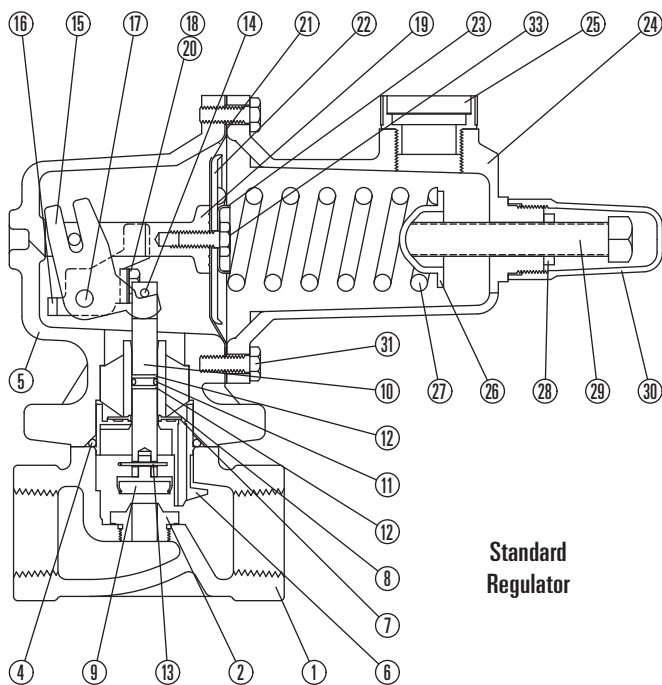

# Parts list



Item	Description	Qty.	Part No.	
			Standard	High Pressure
1	BODY, 1"NPT, STEEL WCB	1	1117899	
	BODY, 2"NPT, STEEL WCB	1	1123940	
2*	SEAT, 3/32" 316 STAINLESS STEEL	1	1118353	
	SEAT, 1/8 316 STAINLESS STEEL	1	1118354	
	SEAT, 3/16" 316 STAINLESS STEEL	1	1117868	
	SEAT, 1/4 316 STAINLESS STEEL	1	1117869	
	SEAT, 3/8" 316 STAINLESS STEEL	1	1117870	
	SEAT, 1/2" 316 STAINLESS STEEL	1	1117871	
3	SCREW, HEX HEAD (NOT SHOWN)	2	1117852	1121125
4*	O-RING, VITON®	1	1117900	
5	DIAPHRAGM CASE, ALUMINUM (STANDARD), STEEL WCB (HIGH PRESSURE)	1	1117900	1126361
6	BOOST BODY, DELRIN (AVAILABLE IN SS FOR HT OPTION)	1	1117902	1117902
7	STABILIZER, NITRILE	1	1117840	
8	STEM GUIDE, 316 STAINLESS STEEL	1	1117865	
9*	DISK ASSEMBLY, 316 STAINLESS STEEL / NEOPRENE	1	1117878	
	DISK ASSEMBLY, 316 STAINLESS STEEL / NYLON	1	1117879	
10	STEM, 316 STAINLESS STEEL	1	1117867	
11*	O-RING, VITON®	1	1016614	
12	BACK UP RING, TEFLON®	2	1117851	
13	HAIR PIN CLIP, STAINLESS STEEL	1	1117850	
14	PIN, STAINLESS STEEL	1	1117849	
15	LEVER, STEEL PLATED	1	1117866	
16	LEVER RETAINER, STEEL PLATED	1	1117888	
17	LEVER PIN	1	1117838	
18	LEVER CAP SCREW	2	1117847	
19	POST AND PIN ASSEMBLY	1	1117883	1124675
20	LOCK WASHER	2	1117848	
21	DIAPHRAGM, NITRILE (STANDARD), NEOPRENE (HIGH PRESSURE)	1	1117841	1120635
22	DIAPHRAGM HEAD, STEEL PLATED (STANDARD), 410 STAINLESS STEEL (HIGH PRESSURE)	1	1117874	1120664
23	SPRING SEAT, STEEL PLATED (STANDARD)	1	1117874	-
	SPRING SEAT FOR 10-95 SPRING ONLY (STANDARD)	1	1117884	-
	DIAPHRAGM LIMITER (HIGH PRESSURE)	1	-	1119218
24	UPPER HOUSING, ALUMINUM (STANDARD), STEEL WCB (HIGH PRESSURE)	1	1117901	1122811
25	VENT ASSEMBLY, PLASTIC	1	11035	
26	UPPER SPRING SEAT, STEEL PLATED	1	21080	
27	SPRING, 5-20 PSIG, YELLOW (STANDARD)	1	1117839	-
	SPRING, 15-40 PSIG, GREEN (STANDARD)	1	11039	-
	SPRING, 35-80 PSIG, BLUE (STANDARD), 140-250 PSIG (HIGH PRESSURE)	1	11040	
	SPRING, 70-150 PSIG, RED (STANDARD), 240-500 PSIG (HIGH PRESSURE)	1	11041	
	SPRING, 10-95 PSIG, NONE (STANDARD)	1	11211	-
28	JAM NUT, STEEL PLATED	1	1117876	
29	ADJUSTING SCREW, STEEL PLATED	1	1117846	
30	CAP, PLASTIC	1	1117889	
31	CAP SCREW, STEEL PLATED	8	11044	11151
32	NAME PLATE, ALUMINUM	1	21094	
33	CAP SCREW, STEEL PLATED (STD. & HIGH PRESSURE)	1	1117847	1122739
		1	-	-
34	RIVET	2	1117817	
35*	O-RING, TEFLON® (HIGH-PRESSURE)	1	-	1032315
36*	O-RING, TEFLON® (HIGH-PRESSURE)	2	-	1021235

\* Recommended Spare Part

---

## Why you can depend on genuine Norriseal-Wellmark products

- In-house engineering and technical support
- In-depth applications experience
- Award-winning innovation and ongoing product development
- ISO 9001 certified manufacturing
- Over five decades of industry service
- Compliance with all industry standards and specifications
- Responsive service and prompt delivery
- Field support available worldwide

Contact Norriseal-Wellmark for more information about our products and services.

### Texas

Houston . . . . . 713-466-3552

### Oklahoma

Oklahoma City . . . . . 405-672-6660

### Louisiana

Broussard . . . . . 337-837-3223



Follow us on LinkedIn.

### Request for Quote

NRS\_RFQ@championx.com



[NorrisealWellmark.com](https://NorrisealWellmark.com)

---

Norriseal-Wellmark | 11122 W Little York Rd | Houston, TX 77041

This document is provided on an "as is" basis without warranties of any kind. Norriseal-Wellmark DISCLAIMS ALL WARRANTIES, EXPRESS OR IMPLIED, INCLUDING, BUT NOT LIMITED TO, IMPLIED WARRANTIES OF MERCHANTABILITY, FITNESS FOR A PARTICULAR PURPOSE OR SUITABILITY FOR ANY PURPOSE, TITLE, AND NON-INFRINGEMENT. While reasonable care has been taken in the preparation of this document, Norriseal-Wellmark does not represent or warrant that the contents of this document are accurate, complete, reliable, current or error-free.